

SDD 912

Pressure relief valves



INSTRUCTIONS MANUAL

BAMO MESURES

22, Rue de la Voie des Bans - Z.I. de la Gare - 95100 ARGENTEUIL

Tél : (+33) 01 30 25 83 20 - Web : www.bamo.fr

Fax : (+33) 01 34 10 16 05 - E-mail : info@bamo.fr

Pressure relief valves
SDD 912

20-12-2011

912 M1 02 B

PLAS

912-02/1

1. MANUFACTURER DECLARATION

BAMO Mesures SAS, declares that the pressure relief valves, SDD 912, due to their non ability to be used with dangerous fluids because of their Nominal Diameters and Pressure Class, are not concerned by the Directive **EC 97/23 CE** relative to pressure apparatus.

2. APPLICATION

A pressure relief valve SDD 912 limits the static pressure to a constant and maximal settled value by opening the outlet (to the discharge line) when the pressure is overriding.

All wetted parts are in plastics.

Without any metallic parts exposed to the atmosphere it allows a location in corroding vapours.

The seat seal and o-ring seals are in EPDM or FPM according to the model and connections.

The SDD 912 valves may be used as pressure relief valves on volumetric pumping system and to protect all pipe red of pressure overrides.

These equipment protection devices may be fitted in any position, in line, or on by-pass according to the application.

3. TECHNICAL FEATURES

Body:	PVC
Seat seal and O-rings:	EPDM (ND 32 to ND 80) or FPM (ND 32 to ND 50)
Relief pressure:	1 to 10 bar
Pressure class:	PN 10 (at 20°C) ; [bar]
Temperature limits:	+10 ... +50°C
Inlet / outlet size:	ND 32 to ND 80
Hysteresis:	Approximately 0.5 bar
Connections (ND 32 to ND 50):	PVC unions or PVC spigot ends
Connections (ND 65 & ND 50):	Inlet: PVC flange; Outlet: PVC spigot ends
Flow rate limit:	3 m/s as a maximum

Operating conditions: pressure vs. temperature

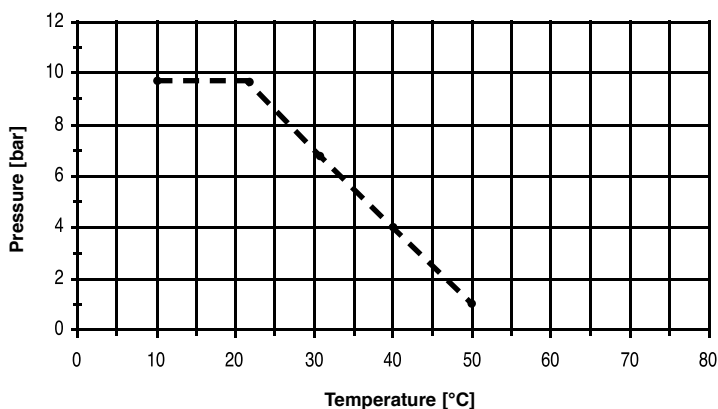

4. MOUNTING

- Connect the valve to a pipe free from any mechanical stress and, when it is possible, with dismantable connections.
- Respect the flow direction shown by the arrow on the body.
- Install a filter to reduce deposits when the fluid contains particles.
- Mount the valve in any position.

5. ADJUSTMENT

To adjust the settled value of the pressure relief, take of the protective cap, unscrew the lock nut, and proceed as following:

- Screw on the adjustment knob to increase the pressure relief value.
- Unscrew the adjustment knob to decrease the pressure relief value.

Use a pressure gauge fitted on the line to adjust the pressure relief value.

The piston will be damage by an excessive tightening of the adjustment knob.

6. CHEMICAL COMPATIBILITY

First of all, verify the chemical compatibility of the valve materials (body, seat seal and o-rings, connections) with the fluid in use.

7. CODES NUMBER AND REFERENCES

SDD 912 with spigot ends		
ND	Sealing EPDM	Sealing FPM
ND 32	912 001	912 011
ND 40	912 002	912 012
ND 50	912 003	912 013

SDD 912 with unions		
ND	Sealing EPDM	Sealing FPM
ND 32	912 101	912 111
ND 40	912 102	912 112
ND 50	912 103	912 113

SDD 912, inlet: PVC flange, spigot end on outlet	
DN	Joints EPDM
DN 65	912 004
DN 80	912 005

8. DIMENSIONS (/mm)

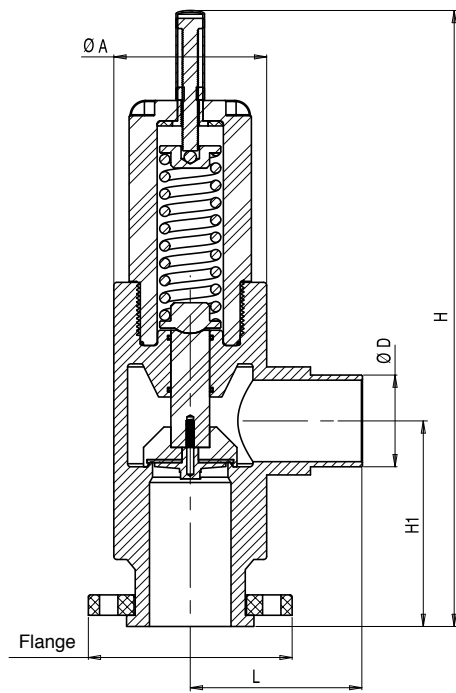

ND 65 & ND 80

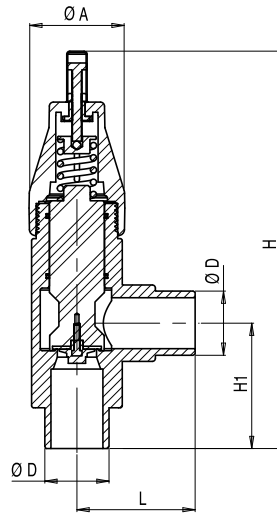

DN 32 ... 50 - spigot ends

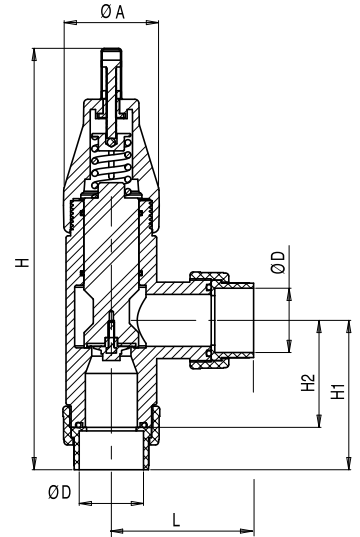

ND 32 ... ND 50 unions

ND	D [mm]	A [mm]	H [mm]	H1 [mm]	L [mm]	H2 [mm]	L1 [mm]	Mass [Kg]
ND 32	40	80	305* - 335	88* - 105	80* - 105	75	75	-
ND 40	50	80	341* - 360	110* - 125	95* - 120	90	85	-
ND 50	63	94	395* - 410	127* - 145	115* - 140	105	100	-
ND 65	75	150	605	202	155	-	-	-
ND 80	90	150	605	202	170	-	-	10

*: Spigot ends